



MALAYSIA---CHINA---HONG KONG

Company Profile

Guangdong Jide Technology Co.,Ltd, founded in 2007, is a modern technology-based enterprise specializing in the research and development of own brand green technology products, which include magnetic levitation compressor chiller, residential/commercial intelligent full DC inverter cooling and heating units, industrial and agricultural drying units to provide clean and energy-saving solutions for customers on earth. In order to better provide consultancy, purchasing and installation services to the Asian market, we have also set up Jide Technology (M) SDN BHD, Jide International Development Limited(Hong Kong) and we are committed to providing safe, efficient and energy-saving customized energy storage solutions for the sustainable development of a green planet.

Service

1 Project consulting and solutions design:

air-conditioning and hot water projects for hotels, schools, hospitals, factories, resorts, beauty salons, etc

Industrial and agricultural drying projects:

agricultural and sideline products tobacco, chemical raw materials, sludge, etc.

2 Project site visit and design energy-saving solution

3 Installation guide

4 Import and Export support

晉裕

Company Profile

FORTUNE ASCENT INT'L TRADE DEVELOPMENT LIMITED (since 2002)

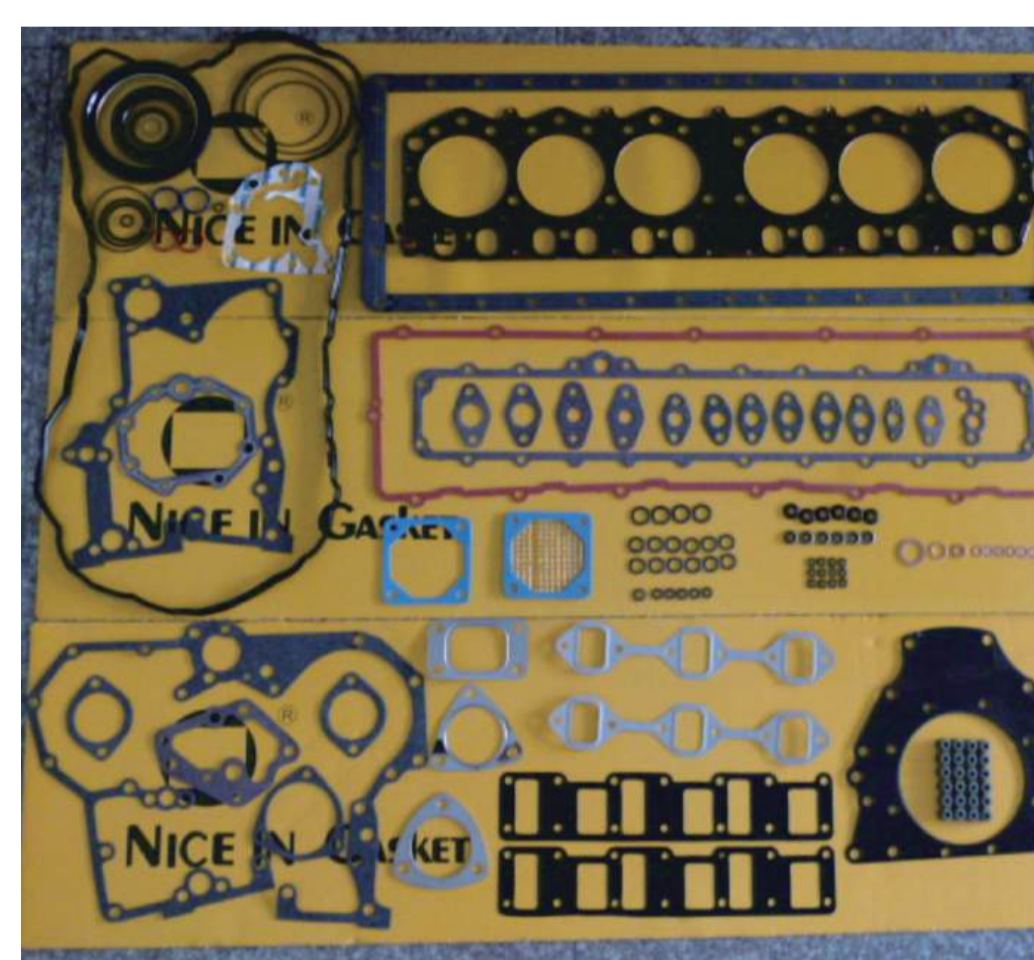
晉裕國際貿易發展有限公司成立於2002年，一直秉承“誠信立業、專業進取”的宗旨，為海內外客戶提供商業諮詢以及優質產品的供應鏈服務，主營產品包括：綠色能源設備、塑膠製品、汽車配件、五金製品、紡織品、服裝、機械設備、家用電器等。服務對象主要為醫院、學校、酒店、別墅、公寓及餐飲行業等。

FORTUNE ASCENT INT'L TRADE DEVELOPMENT LIMITED, was established in 2002. It has been adhering to the tenet of "establishing business with integrity and professionalism" and providing business consulting and supply chain services of high-quality products to customers on earth. The specific categories include: green energy equipment, plastic products, auto parts, hardware products, textiles, clothing, machinery equipment, household appliances, etc. Major customers include hospitals, schools, hotels, villas, apartments and catering industries.

**inverter heat pump
equipment**



autoparts



clothing



vaccum bag



Prefabricated food



Contact us

Shirley Lu (Managing Director)

Unit 2703B, 27/F., 148 Electric Road, North Point, Hong Kong.



香港北角電氣道148號27樓2703B室



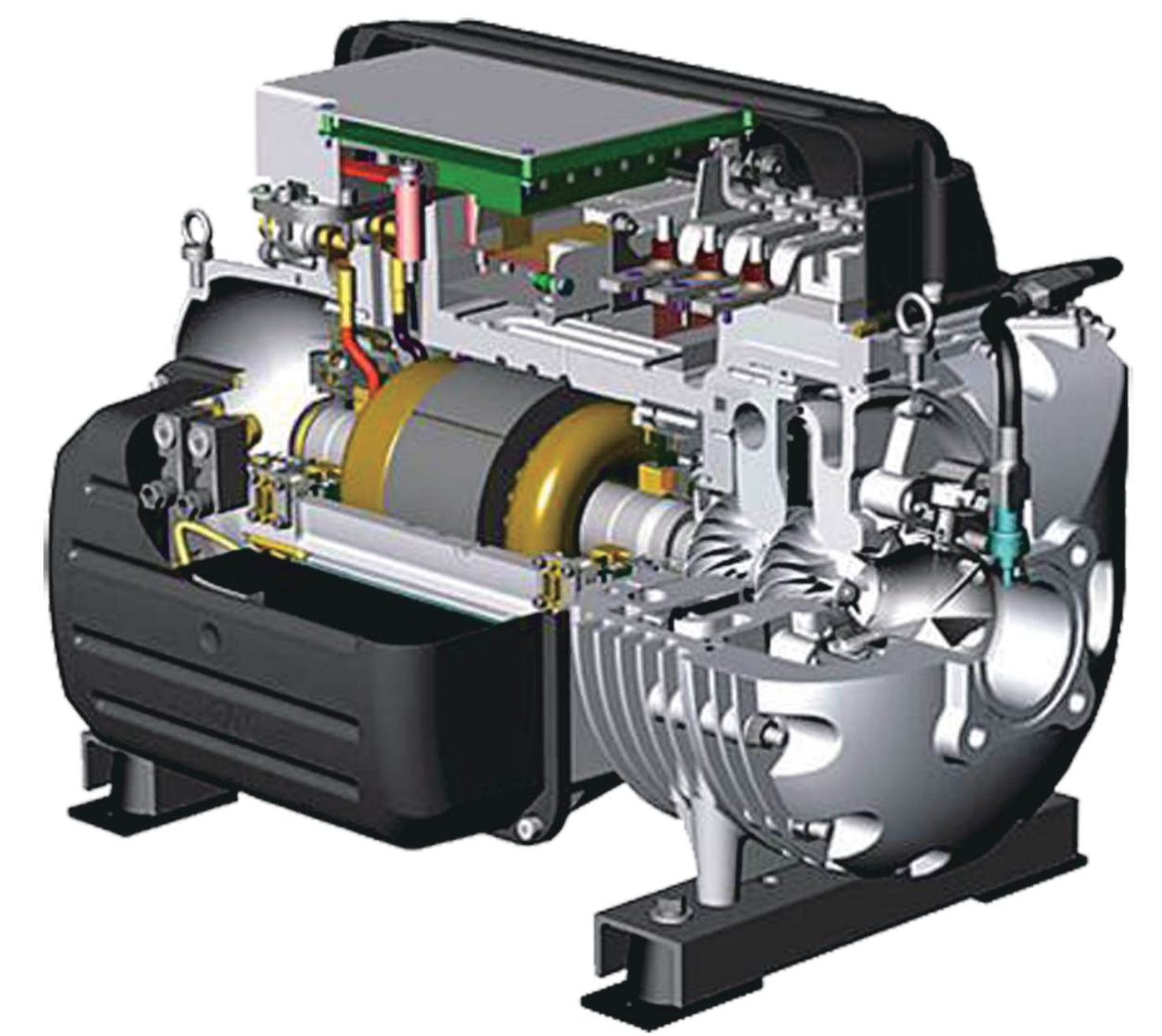
+852 36789405



+86 13802482962

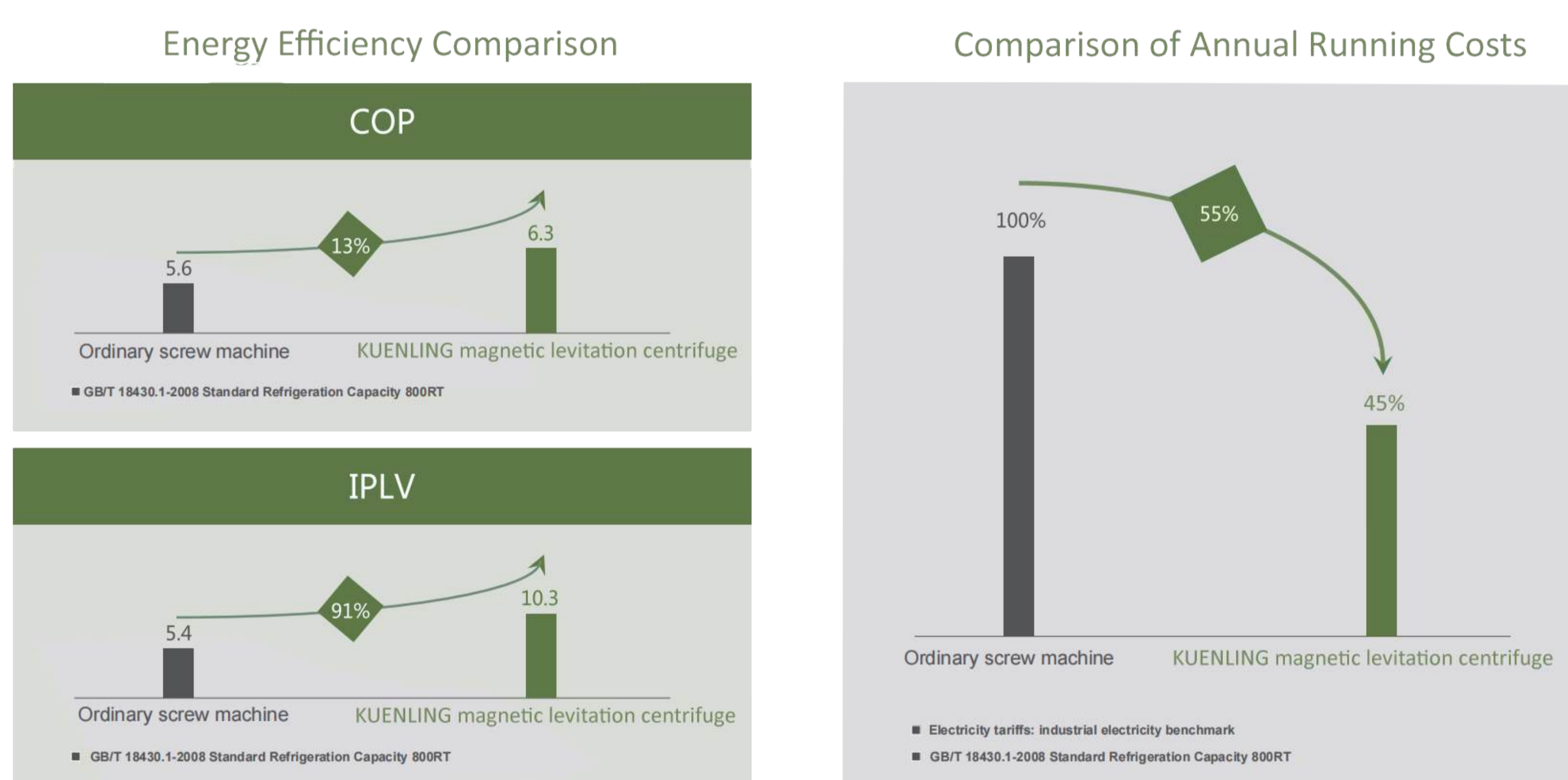
Magnetic levitation compressor chiller

KUENLING AIR EXCLUSIVE DISTRIBUTOR in MALAYSIA

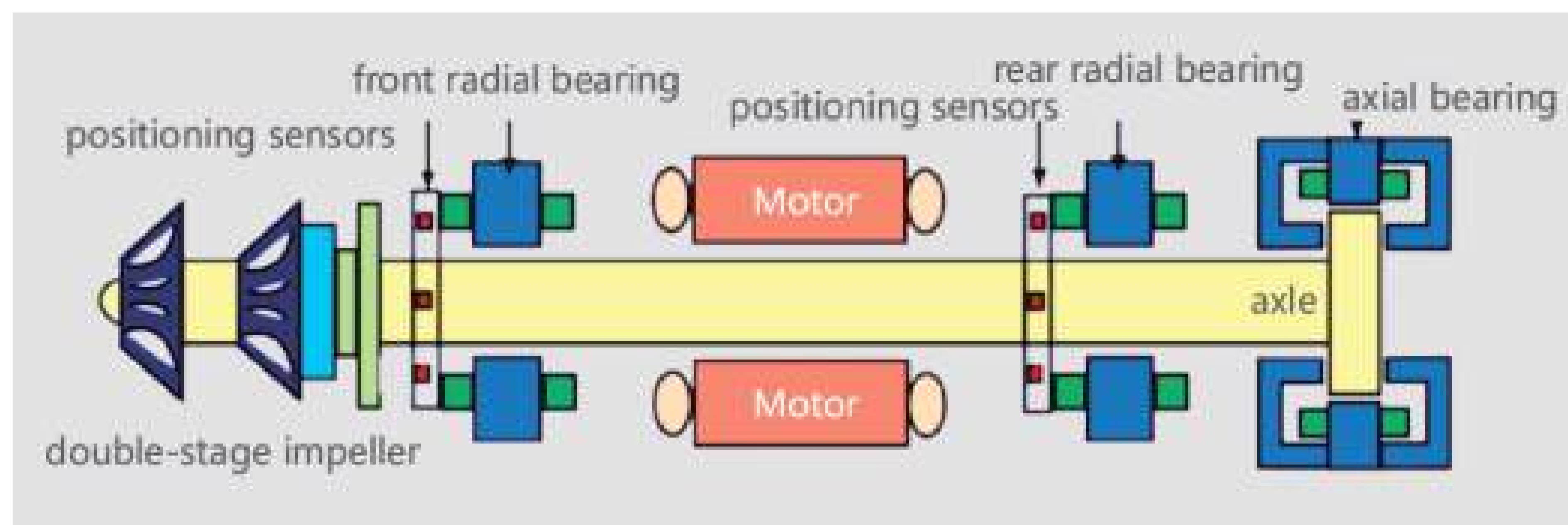


Advantage

1 Energy-Saving



2 Oil-Free Operation



3 Cloud Service System (Optional)

4 Quiet & Environmentally Friendly

5 Stable & Durable

6 PERFECT SERVICES

Application



Jide heat pump unit family

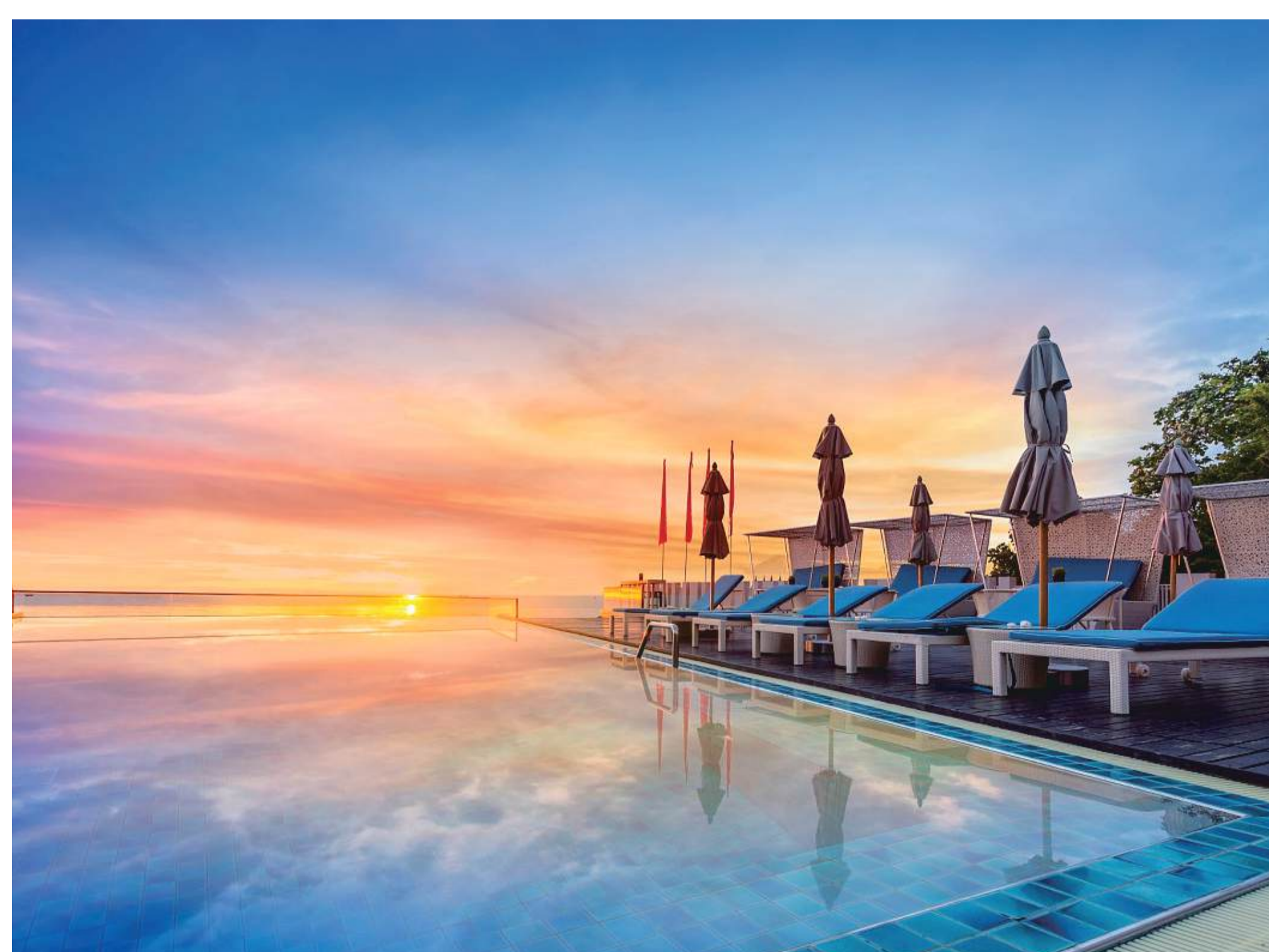


Application

HOSPITAL



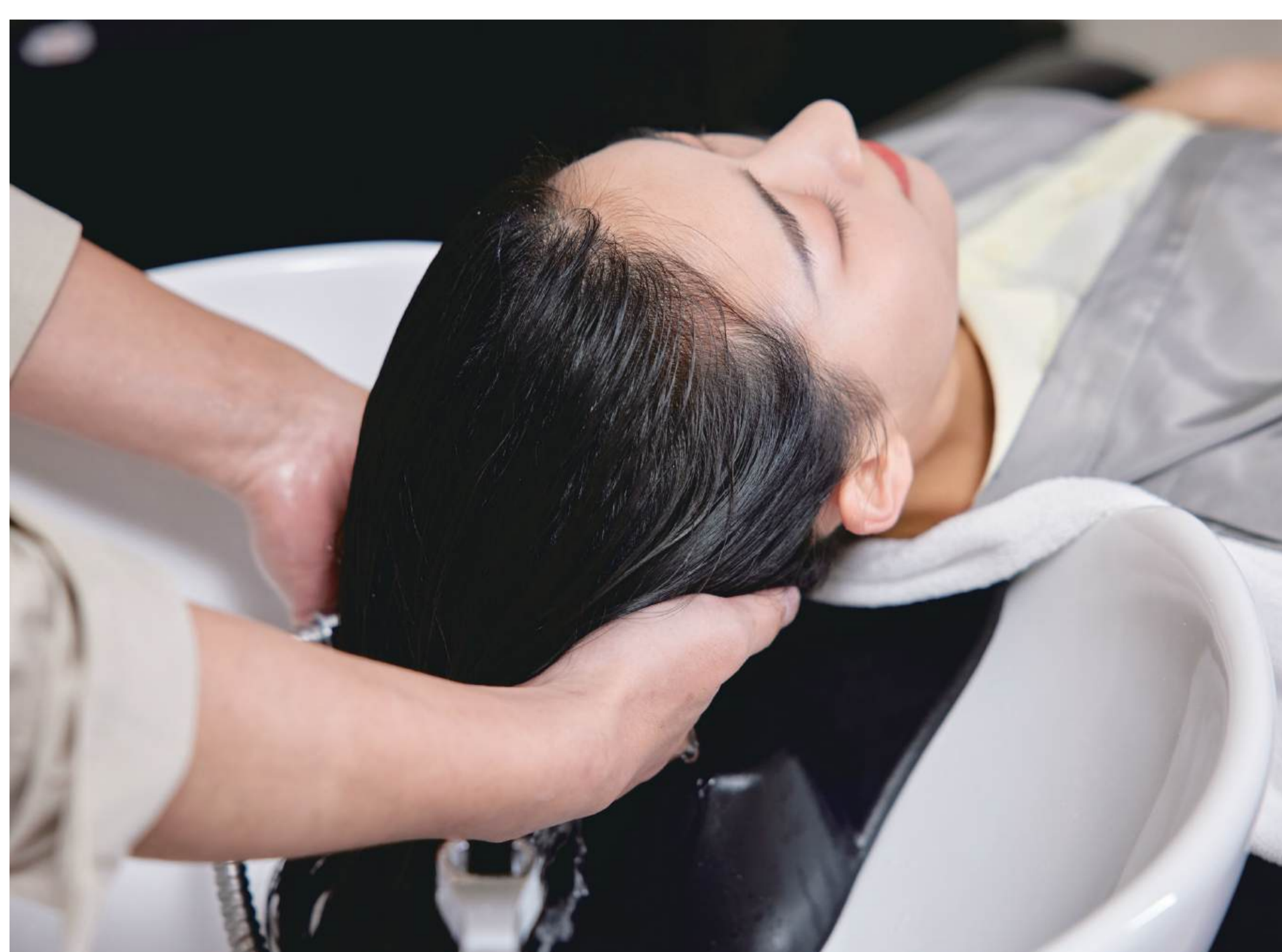
HOTEL



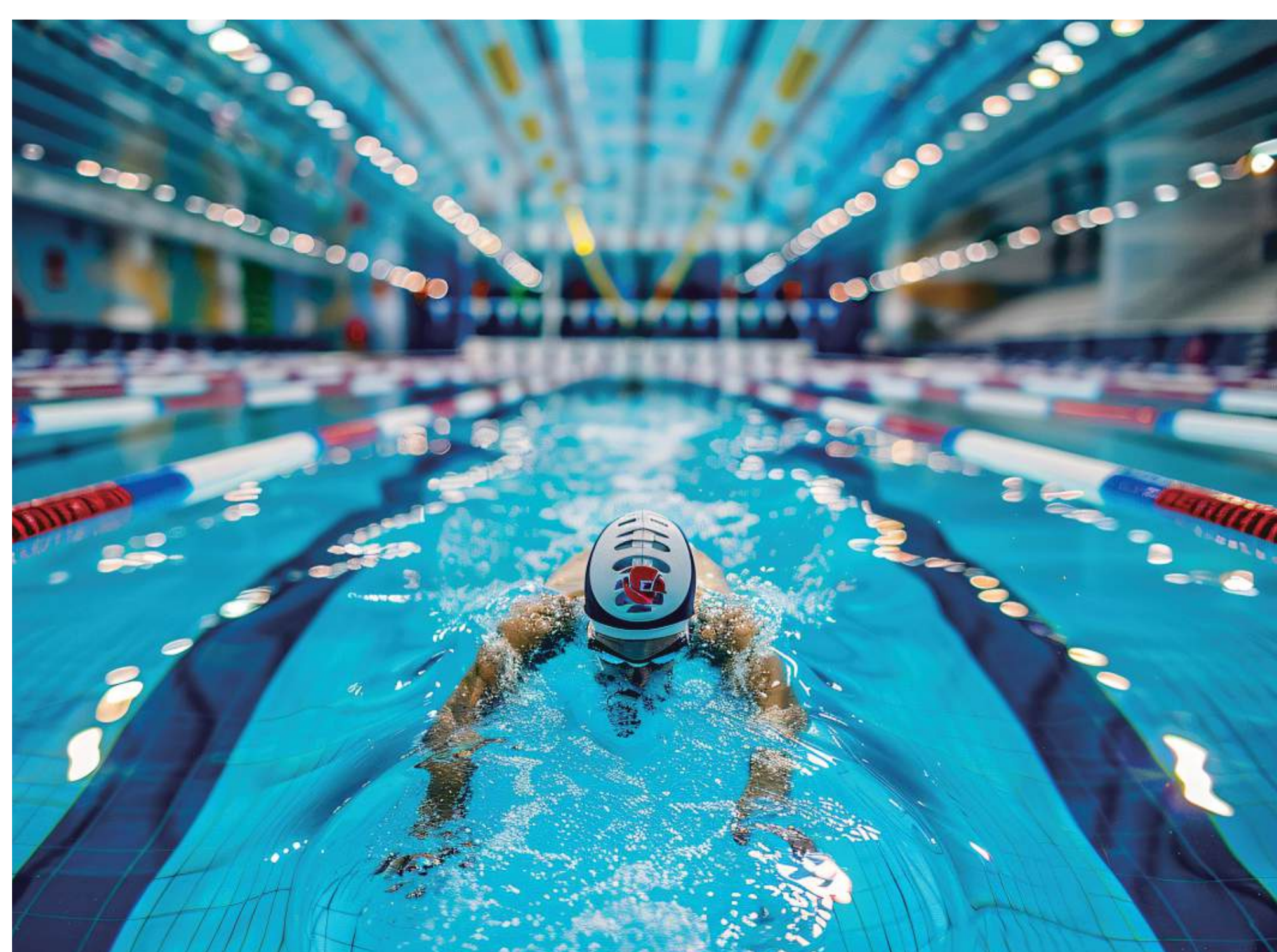
SCHOOL



BEAUTY SALON



SWIMMING POOL



REAL ESTATE



Intelligent full DC inverter Heating&cooling unit



Full DC Inverter
Compressor



Full DC
Fan Motor



Full DC Inverter
Circulation Pump






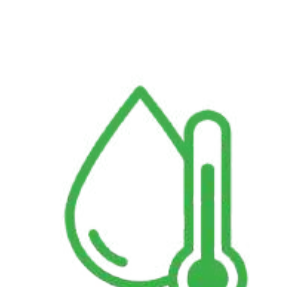
High Efficiency
Titanium Casing
Heat Exchanger

OR

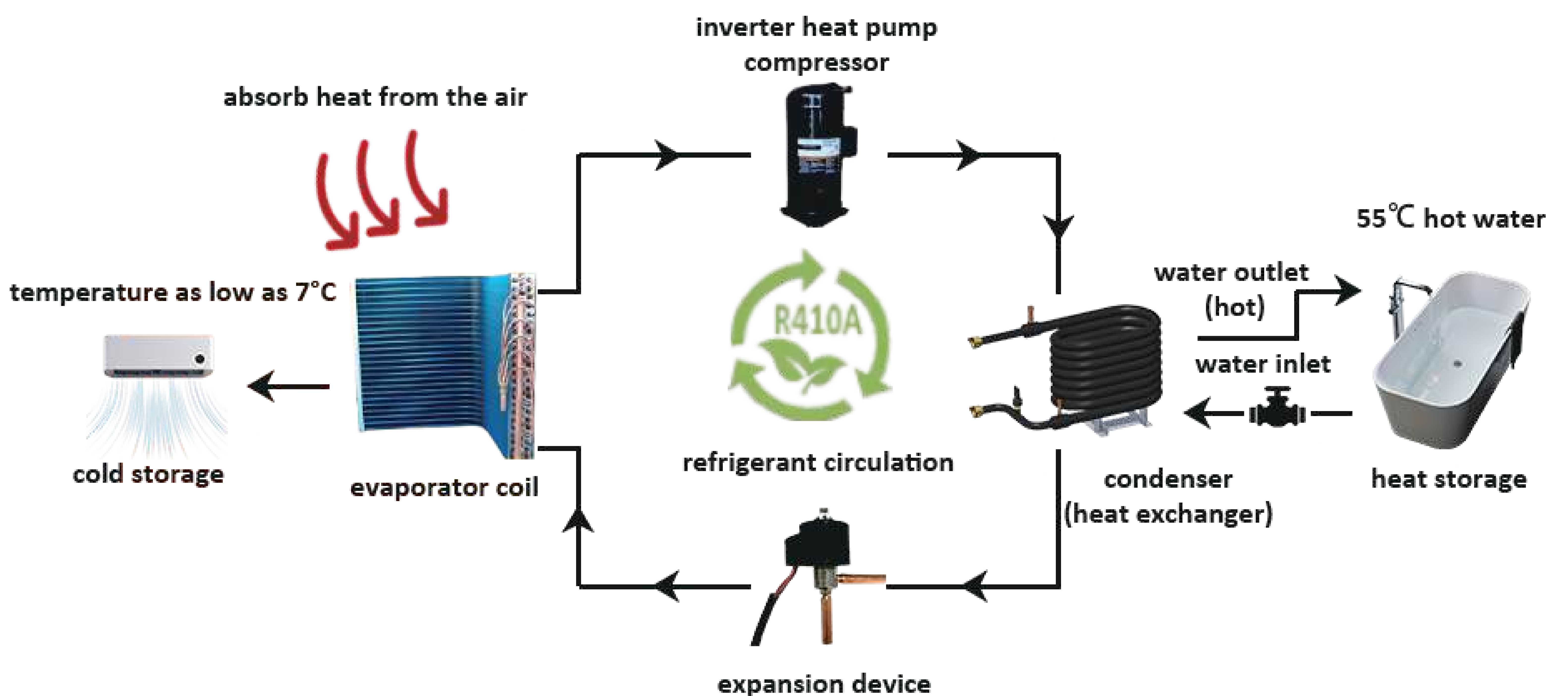
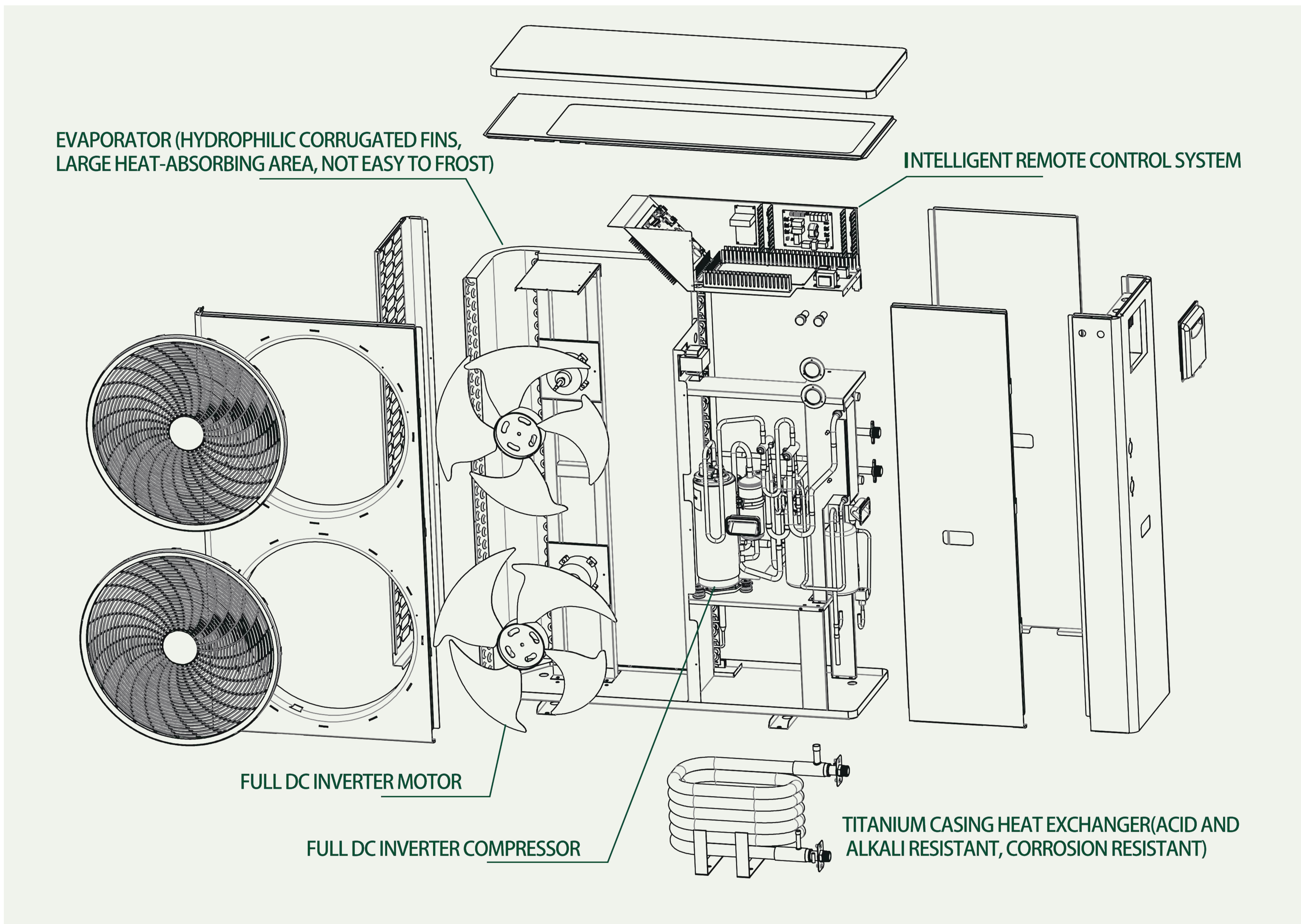


Plate Heat
Exchanger

ADVANTAGES

-  much lower cost, higher efficiency
-  Inverter heating and cooling dual function, ECO friendly, energy saving
-  Intelligent remote control system
-  Get Free 55 °C hot water when cooling mode is on

Intelligent full DC inverter Heating&cooling unit



Industrial and agricultural heat pump drying unit

low energy consumption

Energy saving and eco-friendly, high efficiency and safe

wide range of applications

intelligent remote control system

intelligent temperature control and dehumidification

Precise temperature control

Multiple protection

Air volume adjustable

Applications

FOOD INDUSTRY



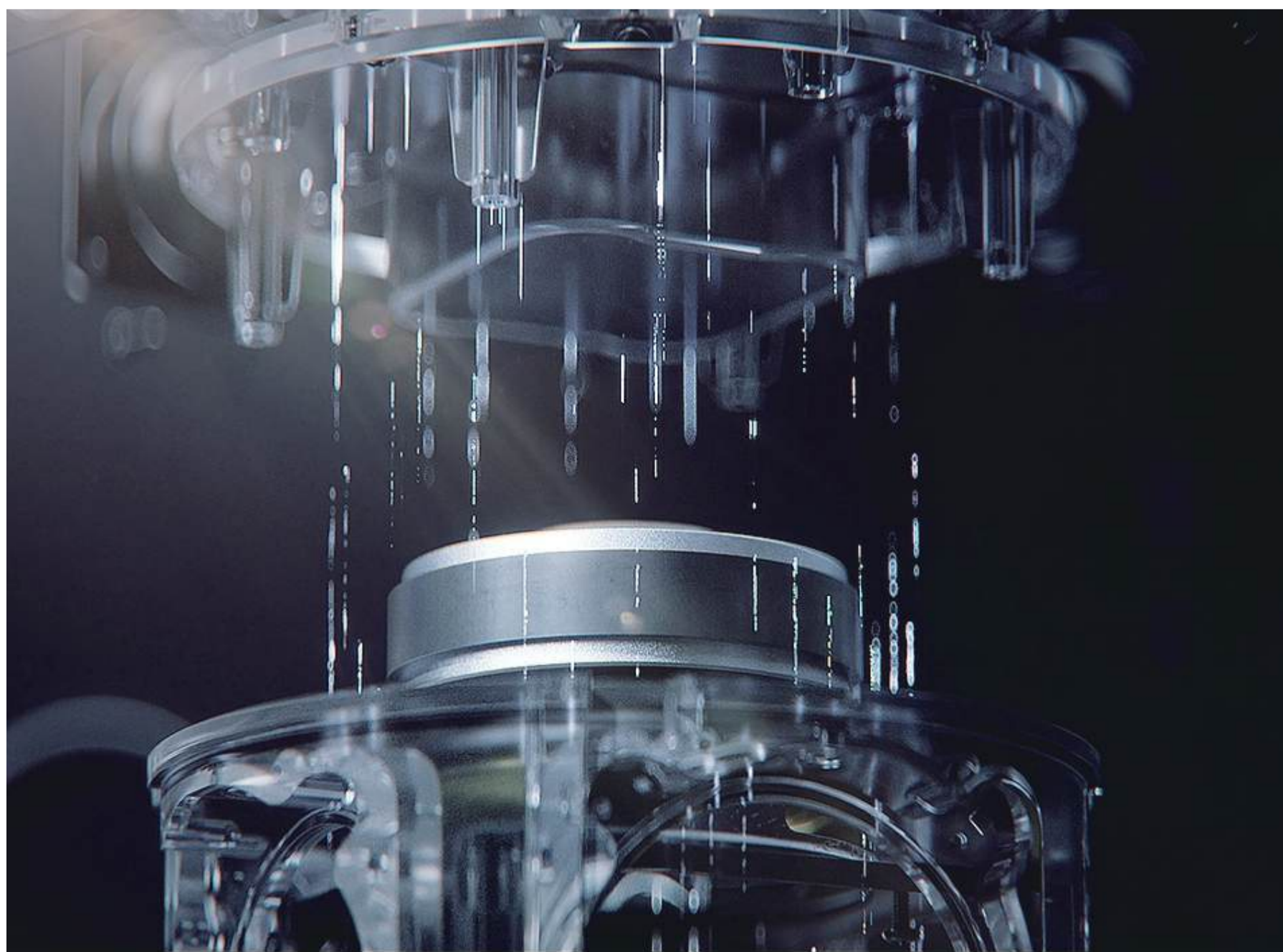
PLANTING BASES



BREEDING BASES



ELECTROPLATED INDUSTRY



PRINTING AND DYEING INDUSTRY



TIMBER INDUSTRY

