

常用热泵机组

Normal heat pump units



应用范围:

Applications:

- 1 中央热水 (家用、商用、泳池恒温)
Centralized hot water (domestic, commercial, pool constant temperature)
- 2 别墅、公寓、酒店宾馆、学校医院、泳池桑拿、休闲会所、美容美发馆、企事业单位、大型房地产商等中央热水供应
Centralized hot water supply for villas, apartments, hotels, schools and hospitals, swimming pools and saunas, leisure clubs, beauty salons, enterprises and public institutions, large real estate developers, etc.
- 3 农业综合节能恒温: 屠宰场、大棚、种植基地 (花、蔬菜等) 养殖基地、孵化基地等
Comprehensive energy-saving thermostat in agriculture: abattoirs, greenhouses, planting bases (flowers, vegetables, etc.), breeding bases, incubation bases, etc.
- 4 工业综合节能高温热水: 制造企业、电镀企业、印染行业、木材行业等 在生产过程中对高温热水有需求企业
Industrial energy-saving high-temperature hot water: manufacturing enterprises, electroplating enterprises, printing and dyeing industry, timber industry, etc.



智能变频双效机组

Intelligent full DC inverter Heating&cooling unit



- 1 关键部件完美配, 节能环保高效
Outstanding key components fit perfectly
- 2 变频冷暖双效, 节能环保高效
Inverter heating and cooling dual function, ECO friendly, energy saving and high efficiency
- 3 智能远程控制系统
Intelligent remote control system
- 4 制冷加热水模式时, 55度热水免费
Free 55 degree hot water when cooling and heating water mode

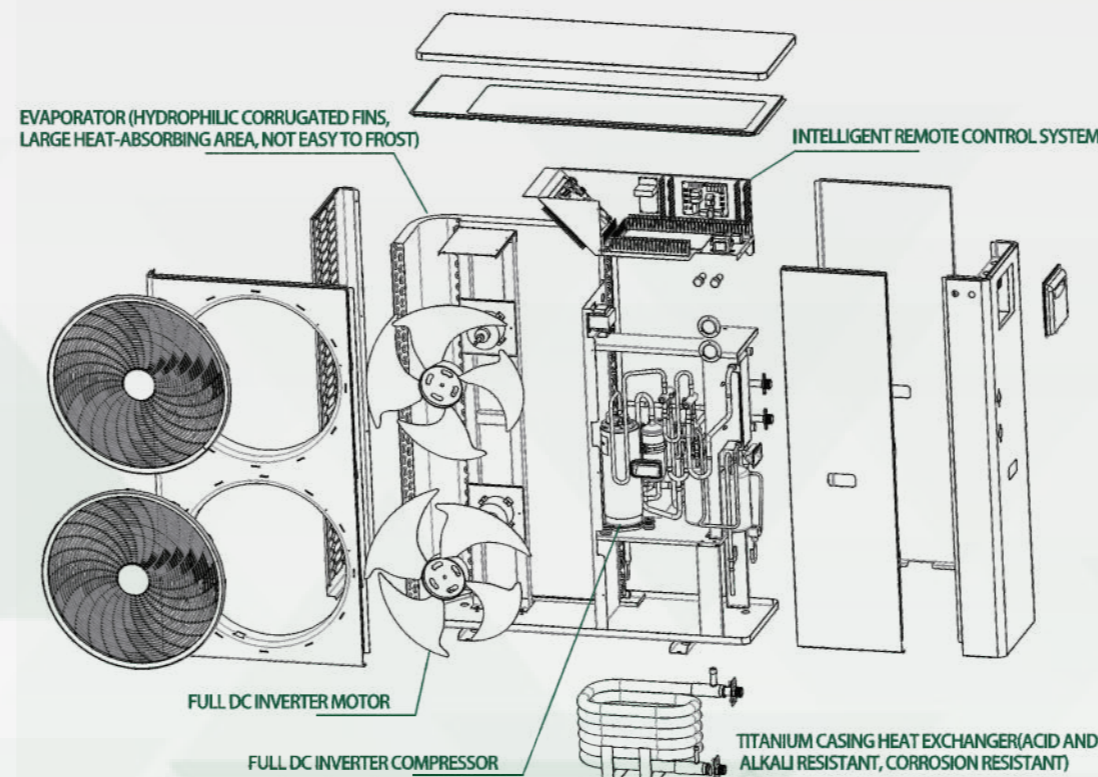

绿色能源解决方案伙伴

Green Energy Solutions Alliance

劉倅銓

Low Sing Chyuan



wechat account

盧雪梅

Shirley Lu



wechat account

張靖怡

Jennie Cheung



wechat account

JIDE TECHNOLOGY(M) SDN.BHD.

T2A-13-03, 3 Towers, Jalan Ampang, 50450 Kuala Lumpur, Malaysia

GUANGDONG JIDE TECHNOLOGY CO.,LTD (GUANGDONG, CHINA)

JIDE INTERNATIONAL DEVELOPMENT LIMITED (HONG KONG)

工农业热泵烘干机组

Industrial and agricultural heat pump drying unit

节能环保高效安全
Energy saving and eco-friendly, high efficiency and safe

应用范围广
wide range of applications

智能控温除湿
intelligent temperature control and dehumidification

智能远程控制系统
intelligent remote control system

能耗低
low energy consumption

Precise temperature control

Multiple protection

The air volume is adjustable

1 节能环保
Energy saving & eco-friendly

2 保持材料品质
Remain Material Quality

4 高效
High Efficiency

3 智能控制
Intelligence control

5 卫生
Hygiene

应用范围:

Applications:

农业节能烘干: 农副产品(槟榔、核桃、罗汉果、红枣等)、粮食作物、瓜果蔬菜、药材等烘干

工业节能烘干: 印刷品烘干、布料烘干、印染烘干、电镀烘干、化工制药烘干等

Agricultural energy-saving drying: agricultural products (betel nut, walnut, pepper, jujube, etc.), grain crops, fruits and vegetables, medicinal herbs, etc

Industrial energy-saving drying: printing drying, fabric drying, printing and dyeing drying, electroplating drying, chemical and pharmaceutical drying, etc.

磁悬浮压缩机冷水机组

Magnetic levitation compressor chiller



1 Energy-Saving

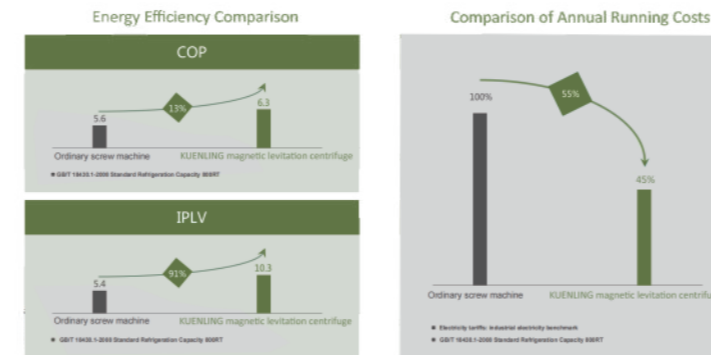

2 Oil-Free Operation

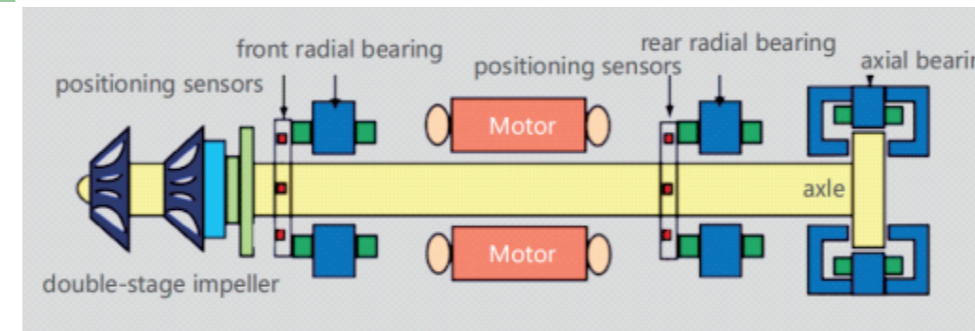

3 Cloud Service System (Optional)

4 Quiet & Environmentally Friendly

5 Stable & Durable

6 PERFECT SERVICES

应用范围:

Applications:



公司简介

Company Profile

Guangdong Jide Technology Co.,Ltd, founded in 2007, is a modern technology-based enterprise specializing in the research and development of own brand green technology products, which include magnetic levitation compressor chiller, residential/commercial intelligent full DC inverter cooling and heating units, industrial and agricultural drying units to provide clean and energy-saving solutions for customers on earth. In order to better provide consultancy, purchasing and installation services to the Asian market, we have also set up Jide Technology (M) SDN BHD, Jide International Development Limited(Hong Kong) and we are committed to providing safe, efficient and energy-saving customized energy storage solutions for the sustainable development of a green planet.

提供服务: Service

1 Project consulting and solutions design:

air-conditioning and hot water projects for hotels, schools, hospitals, factories, resorts, beauty salons, etc

Industrial and agricultural drying projects: agricultural and sideline products tobacco, chemical raw materials, sludge, etc.

2 Project site visit and design energy-saving solution

3 Installation guide

4 Import and Export support